

EES

Electrical residential / light commercial water heater

EES - 30/40/52/66/80/120



Vertical electric water heater for residential / light commercial applications • Two replaceable Incoloy-sheathed elements • Each element is provided with an independent control thermostat (adjustable: 43 - 77 °C) • Secondary protection is provided by a high-limit thermostat with manual reset • PermaGlas Ultra Coat second-generation glass coating technology to prevent corrosion • Replaceable magnesium anode • Optional ancillaries: Unvented kits • Destratification pump kit • Powered anodes • Time controller

Technical specifications

		EES 30	EES 40	EES 52	EES 66	EES 80	EES 120
Electrical data							
Input	kW	3.0	3.0	3.0	3.0	3.0	3.0
Current	A	13	13	13	13	13	13
Elements	-	2	2	2	2	2	2
Power supply	VAC/Hz	230 Vac (-15/+10%)/50 Hz (+/-1HZ)					
General							
Weight empty	kg	36	43	48	64	80	125
Maximum weight	kg	151	198	238	314	380	575
Storage capacity	l	115	155	190	250	300	450
Max. temperature setting	°C	77	77	77	77	77	77
Maximum working pressure	(bar) kPa	(8) 800					
Draw-off capacity							
T_{cold} = 10°C / T_{set} = max. temp. setting							
30 min. ΔT=44°C	l	149	192	229	293	346	506
60 min. ΔT=44°C	l	178	221	258	322	375	535
90 min. ΔT=44°C	l	208	250	288	352	405	565
120 min. ΔT=44°C	l	237	280	317	381	434	594
Continuous ΔT=44°C	l/h	59	59	59	59	59	59
Heating-up time ΔT=44°C	min.	118	159	194	256	307	460
30 min. ΔT=50°C	l	131	169	201	258	305	445
60 min. ΔT=50°C	l	157	194	227	284	330	471
90 min. ΔT=50°C	l	183	220	253	309	356	497
120 min. ΔT=50°C	l	208	246	279	335	382	523
Continuous ΔT=50°C	l/h	52	52	52	52	52	52
Heating-up time ΔT=50°C	min.	134	180	221	281	349	523
30 min. ΔT=55°C	l	119	153	183	234	277	405
60 min. ΔT=55°C	l	143	177	207	258	300	428
90 min. ΔT=55°C	l	166	200	230	281	324	452
120 min. ΔT=55°C	l	190	224	253	305	347	475
Continuous ΔT=55°C	l/h	47	47	47	47	47	47
Heating-up time ΔT=55°C	min.	147	198	243	320	384	576
Shipping data							
Weight incl. packaging	kg	42	49	55	72	90	137
Width packaging	mm	580	580	580	620	680	770
Height packaging	mm	1000	1190	1440	1600	1620	1710
Depth packaging	mm	650	650	650	680	740	840

Dimensions

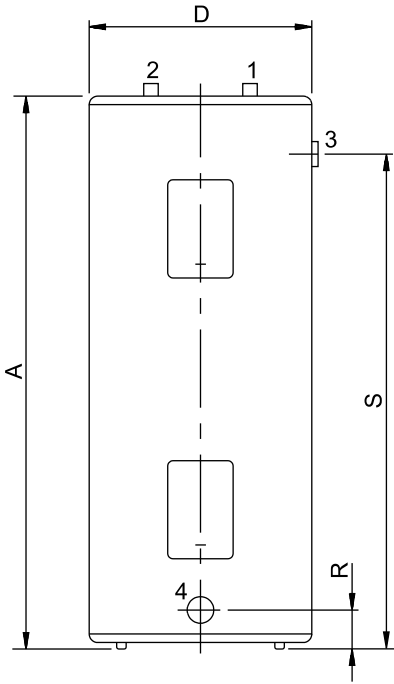

EES 30-120

	EES 30	EES 40	EES 52	EES 66	EES 80	EES 120
A	930	1110	1370	1530	1540	1620
D	520	520	520	560	610	710
F	-	-	-	-	-	-
R	110	110	110	110	110	110
S	730	970	1210	1360	1330	1385
1	Cold water		3/4-14 NPT			
2	Hot water		3/4-14 NPT			
3	T&P valve		3/4-14 NPT			
4	Tank drain valve		3/4-14 NPT			
Dimensions in mm.						

Installation diagrams

Vented

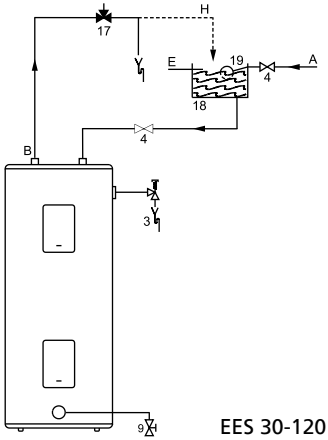

EES 30-120

Unvented

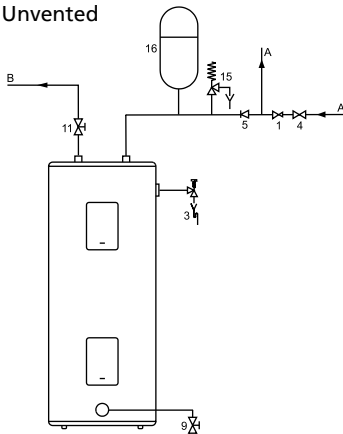

EES 30-120

- 1 Pressure reducing valve
- 3 T&P valve
- 4 Stop valve
- 5 Non-return valve
- 9 Drain valve
- 11 Isolating valve
- 15 Expansion relief valve
- 16 Expansion vessel
- 17 Three way valve
- 18 Water tank
- 19 Float valve

- A Cold water
- B Hot water
- E Overflow pipe
- H Expansion vent pipe

A.O. Smith unvented system kits utilise combination valves.

Further installation and connection details can be found in the Installation & Commissioning Manual.



Electrical diagrams

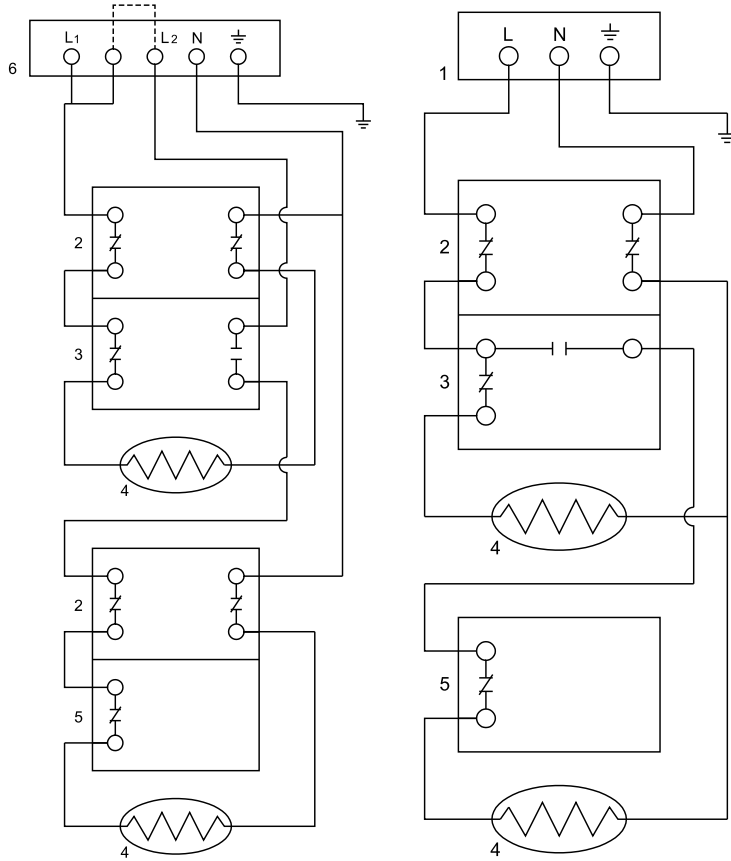

- 1 Standard electrical supply
- 2 Safety thermostat
- 3 Control thermostat with selector switch
- 4 Heating elements
- 5 Control thermostat
- 6 Off peak electrical supply

Data subject to change UK/0810/EES/02
Terms and conditions apply, please refer to our website.